

1DK-14

1.5DK-20

CM-20

DK/CM Series Centrifugal Pump

APPLICATION

- Centrifugal pumps with single impeller are able to offer high flow rates, provide smooth, nonpulsating delivery, and regulate the flow rate over a wide range without damaging the pump.
- For the correct functioning of the pump, use clean water, or non-aggressive liquids charged with small solid impurities.
- To be used in flow irrigation system in gardening, agriculture and industrial fittings.
- The open impeller design allows the pump to handle slightly dirty water.

OPERATING CONDITIONS

- Liquid temperature up to 60°C
- Ambient temperature up to 40°C
- Total suction lift up to 9m
- Continuous duty

CONSTRUCT

PUMP

Pump Body: Cast Iron
Impeller: Brass
Mechanical Seal: Carbon / Ceramic / Stainless Steel

MOTOR

Single Phase
Heavy Duty Continuous Work
Motor Housing: Aluminum
Shaft: Carbon Steel / Stainless Steel
Insulation: Class B / Class F
Protection: IP44 / IP54
Cooling: External Ventilation

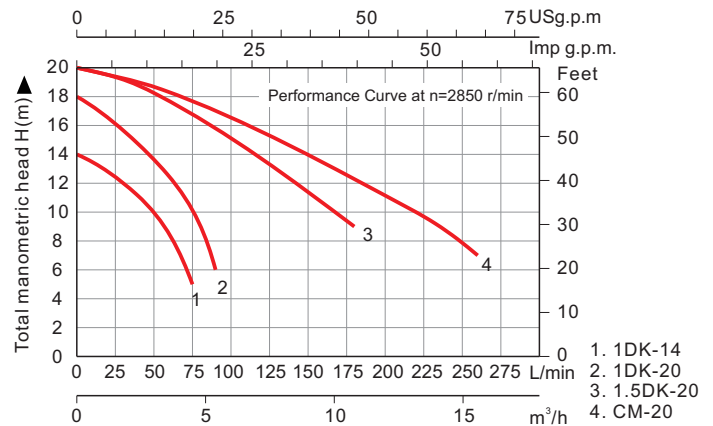
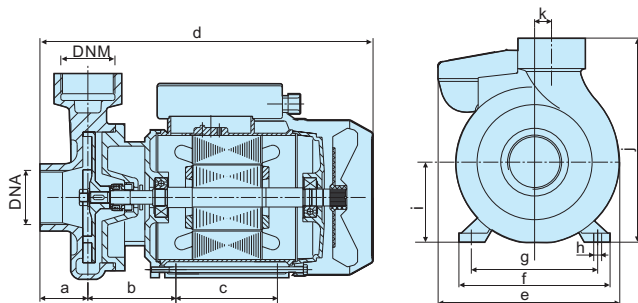

TECHNICAL DATA (220~240V/50Hz)

Model	Single-phase Motor			n=2850/min			Q	H meter																			
	Input max kW	Output Power		Current	Q.max	H.max			Suct.max	US g.p.m	Imp g.p.m	m³/h	L/min														
	kW	kW	HP	A	L/min	m	m																				
1DK-14	0.55	0.37	0.50	2.5	75	14	9	H meter	0	2.64	5.28	7.93	10.6	13.21	15.9	19.8	23.8	37	48	58	68.7						
1DK-20	0.80	0.55	0.75	3.8	90	18			0	2.2	4.4	6.6	8.8	11	13.2	16.5	19.8	31	40	48	57.2						
1.5DK-20	1.10	0.75	1.00	5.2	180	20			0	0.6	1.2	1.8	2.4	3	3.6	4.5	5.4	8.4	11	13	15.6						
CM-20	1.10	0.75	1.00	5.2	260	20			0	10	20	30	40	50	60	75	90	140	180	220	260						
										14	13.5	12.8	12	11	10	8.5	5										
										18	--	16.5	--	14.5	13.5	12.5	10	6									
										20	--	19.5	--	18.8	18.5	17.6	16.5	15.5	12	7							
										20	--	19.5	--	19	18.5	18.3	17.5	16.8	14	12	10	7					

Other voltages and frequencies available on request.

OVERALL & INSTALLATION DIMENSIONS

Model	DIMENSIONS (mm)																PACKAGE DIMENSIONS & G.W.				
	DNA		DNM		a	b	c	d	e	f	g	h	i	j	k	l	m	A	B	H	kg
	Inch	mm	Inch	mm																	
1DK-14	1"	25	1"	25	44	77	80	260	148	118	100	10	63	173	--	--	--	280	165	185	7.4
1DK-20	1"	25	1"	25	44	78	90	298	168	136	112	10	71	191	--	--	--	325	180	210	11.2
1.5DK-20	1.5"	40	1.5"	40	43	78	90	298	168	136	112	10	71	191	--	--	--	325	180	210	13.0
CM-20	1.5"	40	1.5"	40	45	70.5	--	312	168	162	112.5	10	93	219	--	--	--	310	175	225	14.0

